

ARTUSI

MADE IN ITALY

EUROLINX PTY LTD 49-50, MOORE STREET LEICHHAM NSW 2040 AUSTRALIA

MOD. AFG900X TYPE IP:0

AGA APPROVAL CERTIFICATE N. AGA4238G	GAS kPa	
	U-LPG	PROPANE NATURAL
	2.75	1.0

ELECTRICAL APPROVAL CERTIFICATE N. V100536	TOTAL NOMINAL CONSUMPT MJ/h	
	42.8	43.4

LOADING		3220	W
240/415	3N V	50	Hz
S/N 20154102358 042494004 21 01			



GB



**A GUIDE TO USE,
INSTALLATION AND REGULATION
OF YOUR COOKERS**

**MODEL: AFG910B
AFG910W
AFG910X
AFG900X
AFG940X**



ARTUSI

AFG900X

20154102358 042494004 21 01



[Empty box]

The appliance was designed and made in accordance with the European standards listed below:

=> EN 30-1-1, EN 30-2-1 and EN 437 plus subsequent amendments (gas)

=> EN 60 335-1 and EN 60 335-2-6 (electrical) plus relative amendments

The appliance complies with the prescriptions of the European Directives as below:

=> 2006/95 EC concerning electrical safety (BT).

=> 2004/108 EC concerning electromagnetic compatibility (EMC)

=> 2009/142 EC concerning gas safety.

THIS APPLIANCE IS ALSO DESIGNED TO COMPLY WITH AUSTRALIAN STANDARDS.

Oven accessories that could come into contact with foodstuffs are made with materials that comply with the provisions of the 89/109 EC directive dated 21/12/88.

This product complies with EU Directive 2002/96/EC.

The crossed-out dustbin symbol reported on the appliance indicates that the appliance must be disposed of separately from other domestic refuse at the end of its useful life. It must therefore be delivered to a waste recycling centre specifically for electric and electronic equipment or returned to the retailer at the moment of purchase of a new equivalent appliance.

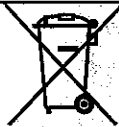

The user is responsible for delivering the appliance to the appropriate collection centre at the end of its useful life. Failure to do so may result in a fine, as provided for by laws governing waste disposal.

Differential collection of waste products for eventual recycling, treatment and environmentally friendly disposal helps reduce possible negative effects on the environment and health, and also enables the materials making up the product to be recycled.

For more detailed information on the available refuse collection systems, refer to the local Municipal Solid Waste disposal centre or the shop where the product was purchased.

Producers and importers are responsible for fulfilling their obligations as regards recycling, treatment and environmentally friendly disposal by directly or indirectly participating in the collection system.

ASSISTANCE AND SPARE PARTS

Before this appliance left the factory it was tested and fine-tuned by specialised expert personnel in order to guarantee its best functioning results.

Any subsequent repairs or adjustments that may be necessary must be done with the maximum of care and attention by qualified personnel.

For this reason we recommend you always contact our Service Centre specifying the brand, the model, its serial number and type of problem you are facing with it. All data related to your appliance are printed on the data label affixed on the appliance as well as on its original packaging.

A duplicate data label is contained in this booklet also. Please attach this label on the handbook or to an accessible surface near by the appliance for easy reference.

This information enables the technical assistant to come and visit you with the correct spares and guarantee a prompt and suitable service.

You will only find original spare parts at our Service Centre and authorised dealers.

CONTENTS

ASSISTANCE AND SPARE PARTS	3
IMPORTANT NOTES AND PRECAUTIONS FOR USE	4-6
DESCRIPTION OF THE APPLIANCE	7-9
INSTRUCTIONS FOR THE USER	10-16
INSTRUCTIONS FOR THE INSTALLER	17-25
TROUBLESHOOTING	26
TECHNICAL FEATURES	26-28

IMPORTANT NOTES AND PRECAUTIONS FOR USE

You have purchased one of our products for which we thank you. We are confident that this new appliance, modern, functional and practical, made with top quality materials, will meet all your demands. This new appliance is easy to use but before installing and using it, it is **important to read this handbook through carefully**. It provides information for a safe installation, use and maintenance. Keep this handbook in a safe place for future reference.

The manufacturer reserves the right to make all the modifications to its products that it deems necessary or useful, also in your interests, without prejudicing its essential functional and safety characteristics. The manufacturer cannot be held responsible for any inaccuracies due to printing or transcription errors that may be found in this handbook.

N.B.: the pictures shown in the figures in this handbook are purely indicative.

- The installation, adjustments, conversions and maintenance operations listed in section «**INSTRUCTIONS FOR THE INSTALLER**» must only be carried out by authorised personnel.
- The installation of all-gas and combi appliances must comply with the standards in force.
- The appliance must only be used for its original purpose, that is, cooking for domestic use. Any other use is considered improper and, as such, dangerous.
- The manufacturer cannot be held responsible for any damage to persons or property resulting from an incorrect installation, maintenance or use of the appliance.
- Once the packaging has been

removed from the outer surfaces and the various inner parts, thoroughly check that the appliance is in perfect condition. If you have any doubts do not use the appliance and call in an authorised person.

- The packaging materials used (cardboard, plastic bags, polystyrene foam, nails, etc.) must not be left within easy reach of children because they are a potential hazard source. All packaging materials used are environmentally-friendly and recyclable.
- The electrical safety of this appliance is only guaranteed if it is correctly connected to a suitable earth system, as prescribed by the electrical safety standards. The manufacturer disclaims all responsibility if these instructions are not followed. Should you have any doubts, seek the assistance of an authorised person.
- Before connecting the appliance ensure that the rating plate data corresponds to that of the gas and electricity supply (see section «**TECHNICAL FEATURES**»).
- **NOT FOR USE IN MARINE CRAFT, CARAVANS OR MOBILE HOMES UNLESS EACH BURNER IS FITTED WITH A FLAME SAFEGUARD.**
- **DO NOT MODIFY THIS APPLIANCE**
- **DOMESTIC USE ONLY**

WARNING - The appliance and its accessible parts become hot during use. Care should be taken to avoid touching heating element. Children less than 8 years of age shall be kept away unless continuously supervised.



IMPORTANT NOTES AND PRECAUTIONS FOR USE

- The oven door glass and the accessible parts will become hot when in use. To avoid burns and scalds young children should be kept away.
- **Do not use this appliance as a space heater.**
- **Do not touch any electrical appliance if hands or feet are wet or damp.**
- **Do not use the appliance bare footed.**
- **Do not pull the power lead to take the plug out of the socket.**
- **Do not leave the appliance outside under the sun, rain, etc.**
- Young children should be supervised to ensure that they not play with the appliance.
- This appliance is not intended for use by persons (including children) with reduced physical, sensory or mental capabilities, or lack of experience and knowledge, unless they have been given supervision or instruction concerning use of the appliance by a person responsible for their safety. Children shall not play with the appliance. Cleaning and user maintenance shall not be made by children with out supervision.
- **WARNING** - In order to prevent the accidental tipping of the appliance, for example by a child climbing on the open oven door, or where users put extreme weight on the door when in open position, the stabilising means must be installed by the installer. Failure to fit the stabilising brackets properly may cause personal burn injuries and damage to the gas pipe.
- Before cooking for the first time, ensure the oven is empty and its door closed, heat the oven at maximum temperature for two hours. This

will allow the protective coating on the interior of the oven to be burnt off and dissipate the associated smells. Ensure adequate ventilation in the kitchen whilst burning off and don't be alarmed by a little bit of smoke during this process.

- When you insert the oven shelf, be sure that the rear stopper of the oven rack must be positioned upwards.
 - Unattended cooking on a hob with fat or oil can be dangerous and may result in fire.
 - Never try to extinguish a fire with water, but switch of the appliance and then cover flame e.g. with a lide or a fire blanket.
 - Danger of fire: Do not store items on the cooking surfaces
 - **Do not use harsh abrasive cleaners or sharp metal scrapers to clean the oven glass door since they can scratch the surface, which may result in shattering of the glass.**
 - **NEVER use sponges or abrasive products, and solvents to remove stains or adhesives on the painted or stainless steel surfaces.**
 - Switch off the oven before removing the fan guard for cleaning. Replace the guard after cleaning in accordance with the instructions.
 - The oven can be equipped with temperature probe. Only use the temperature probe recommended for this oven by our Service Centre.
 - Remove any spillage from the lid before opening.
- Warning:** If the surface is cracked, switch off the appliance to avoid the possibility of electric shock, for hob surfaces of glass-ceramic or similar material which protect live parts)

IMPORTANT NOTES AND PRECAUTIONS FOR USE

- The appliance is not intended to be operated by means of an external timer or separate remote-control system
- Ensure that the appliance is switched off before replacing the lamp to avoid the possibility of electric shock..
- The cookers can be equipped with a small compartment under the oven that can be used for storing things Remember that the surfaces become hot, it is strictly forbidden to place inflammable materials inside.
- **Do not use a steam cleaner to clean a hob, oven or range.**
- The appliance is to be placed directly on the floor and shall not be mounted on a base.
- If the appliance is fitted with a glass lid, this can shatter when heated. Turn off all the burners or disconnect all the plates, and allow them to cool before closing the lid
- Not suitable for installation or operation with aftermarket lids or covers
- Avoid using the oven as a larder or as a saucepan cupboard when you are not using it for cooking; if the oven is turned on accidentally it could cause damage and accidents.
- If you are using an electrical socket near the appliance, make sure that the cables are not touching the cooker and are far enough away from all hot parts.
- When you have finished using the appliance check that all the controls are in the off or closed position, checking that the "0" of the knob corresponds to the "•" symbol serigraphed on the front panel.
- Switch off the electrical supply before you start cleaning or servicing the appliance.
- In the case of a failure or malfunction, turn the appliance off and switch off the electrical supply and do not tamper with it. All repairs or adjustments must be carried out with maximum care and the proper attention of an authorised person.
- For this reason we recommend you call our Service Centre.

DESCRIPTION OF THE APPLIANCE

GENERAL

The cooker is fitted with a gas hob with the electric oven

Each knob on the front panel has a diagram printed above it showing to which burner it refers.

The combination of the different sized burners offers the possibility of various types of cooking.

The oven walls of the two cavity, are fitted with various guide bars (fig. 1) on which the following accessories can be placed (fig. 2):

- Oven shelf Ensure shelf is located with dish and tray stop pointing upwards and at rear of oven.
- Drip tray and Drip tray grid
- handle

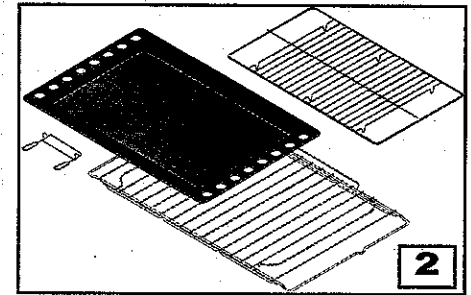

TIMER WITH COOKING TIME

This accessory has a dual function: it signals how much cooking time has elapsed and it also turns the oven off automatically. N.B.: When the pointer of the knob is on «•» position, the oven cannot work. If you use the oven without any programming, check that the timer is on the manual position.

Semi-automatic operation

After having selected a cooking, to set cooking time, first wind the timer up by turning it completely once from left to right and then back to the number of minutes you want, from 0 to 120 minutes: the oven will switch on. Once the programmed time has elapsed the buzzer will ring and the end of cooking time device triggers.

Manual operation

If the cooking time is more than 2 hours, or if you want to use the oven without the timer, turn knob from right to left until the pointer is on the symbol. When the food is cooked do not forget to move the knob pointer round to position «•».

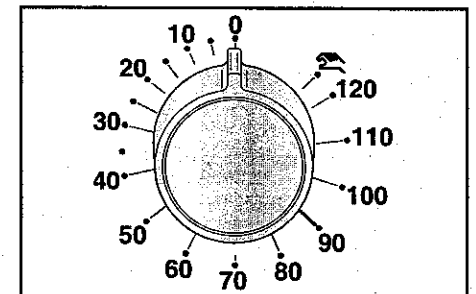
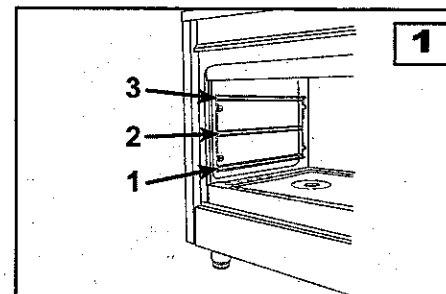
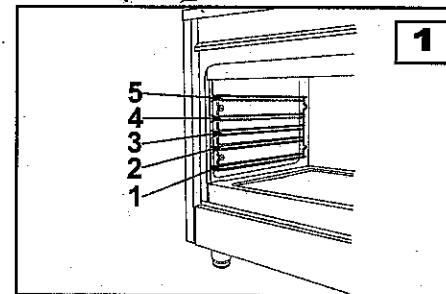

DESCRIPTION OF THE APPLIANCE

DESCRIPTION OF THE CONTROLS

HOB GAS BURNER KNOB (A)

By turning the knob counterclockwise, the following symbols appear:

- = Closed position
- 🔥 = "Full on" position
- 🔥 = "Reduced rate" position

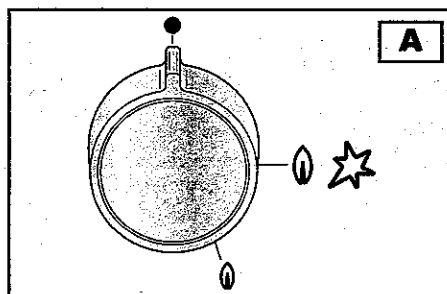

OVEN THERMOSTAT KNOB (B)

By turning the oven knob clockwise you will find the different oven temperature values (from 50°C to Maxi).

OVEN MULTIFUNCTION SELECTOR KNOB (C)

By turning the knob to the right or to the left you will find the following symbols:

- 0 = Oven off
- 🔥 = Oven light on, which stays on for all functions
- 🌀 = Fan on
- 🔥 = Top and bottom heating elements on
- 🔥 = Top and bottom heating elements and fan on
- 🔥 = Bottom heating element and fan on
- 🔥 = Rear heating element and fan on
- 🔥 = Grill + spit heating element on
- 🔥 = Grill heating element and fan on

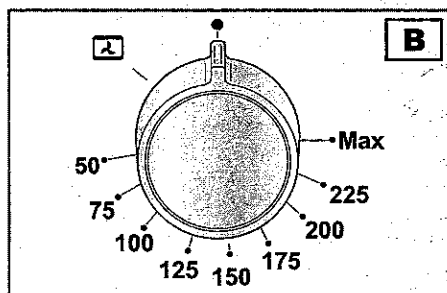

OVEN MULTIFUNCTION SELECTOR KNOB (D)

By turning the knob to the right or to the left you will find the following symbols:

- 0 = Oven off
- 🔥 = Oven light on, which stays on for all functions
- 🌀 = Fan on
- 🔥 = Rear heating element and fan on
- 🔥 = Grill heating element on

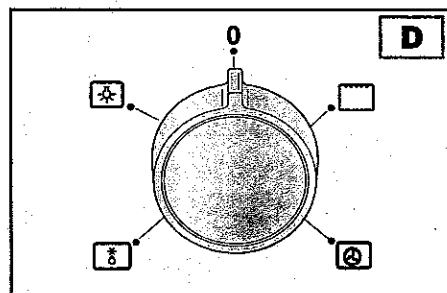

DESCRIPTION OF THE APPLIANCE

ELECTRONIC PROGRAMMER

The programmer can select the following functions:

- Clock (set by keys 2 and 3)
- Minute counter (set by key 1)
- Cooking time (set by key 2)
- End of cooking (set by key 3)
- Manual operation mode (set by key 4)
- Setting time backwards (set by key 5)
- Setting time forward (set by key 6)

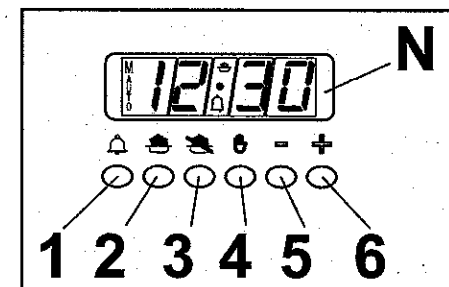

The digital display (N) always shows the time and can display cooking and end of cooking time or the minute counter time by pressing the corresponding push button.

N.B.: At the end of each setting session (except for the minute counter) the programmer turns the oven off. Check when next using the oven, if the programmer is not going to be used, that the latter is set on manual operation (see the instructions given further on).

Setting the time (from 0.01 to 24.00 = hh,mm)

After connecting to the electricity mains or subsequent to a power cut, AUTO and "0.00" will both flash simultaneously on the display.

Press push buttons 2 and 3 simultaneously and start setting the current time by pressing push button 5 or 6. Once set the AUTO symbol will turn off and the 🔥 symbol, for manual operation, will turn on.

Minute counter (from 0.01 to 0.59 = hh,mm)

Press push button 1 and select cooking time with push button 5 or 6. The 🔥 symbol turns on. At the end of the set time the buzzer will go off and the 🔥 symbol turns off.

Semi-automatic operation

(with cooking time from 0.01 to 23.59 = hh,mm)

By pressing push button 2 and setting the length of cooking time with push button 5 or 6, the AUTO and 🔥 symbols will light up and stay on all the time. At the end of the set time the 🔥 symbol will turn off, the AUTO symbol will flash and the buzzer will go off.

Semi-automatic operation

(with end of cooking time from 0.01 to 23.59 = hh,mm)

By pressing push button 3 and setting the end of cooking time with push button 6, the AUTO and 🔥 symbols will turn on and stay on all the time. At the end of the set time the 🔥 symbol will turn off, the AUTO symbol will flash and the buzzer will go off.

Automatic operation

(with the start of cooking time delayed)

First programme cooking time (both the AUTO and 🔥 symbol will turn on) and then the end of cooking time (the 🔥 symbol will turn off) as described previously. The 🔥 symbol will turn on again when baking in the oven starts. At the end of cooking time the 🔥 symbol will turn off, the AUTO symbol will flash and the buzzer will go off.

Manual operation

Manual operation is only possible when the automatic programming has finished or after having cancelled it by pressing push button 4. The AUTO symbol disappears and the 🔥 symbol turns on.

Buzzer

The buzzer will go off at the end of a programme or at the end of the minute counter function and lasts about 7 minutes. The buzzer can be stopped by pressing one of the function push buttons.

Programme start and control

The programme starts after setting. The programme set can be controlled at any time by pressing the corresponding push button.

Correcting/cancelling the programme setting

An automatic function programming error will occur if the time shown on the clock is between the cooking start time and cooking end time. This error will be signalled immediately by a buzzer and the AUTO symbol will flash. A setting error can be corrected by altering the duration or end of cooking time. Any programme that has been set can be corrected at any time by pressing the corresponding programming key and then key 5 or 6. To cancel a programme, correct the time set bringing it to a value of "0.00". If functioning time is cancelled the end of functioning is cancelled too and vice versa. The oven turns off automatically and the AUTO symbol flashes. Press key 4 to set the programmer on manual operation. The right time cannot be corrected when the automatic operation programme is working.

INSTRUCTIONS FOR THE USER

HOB: GENERAL NOTES ON SAFETY

- When using the burners, do not leave the appliance unsupervised. Ensure that children and the infirm do not play with the appliance. In particular, make sure that pan handles are positioned correctly and supervise the cooking of foods which use oils and fats, as these are highly inflammable.
- DO NOT SPRAY AEROSOLS IN THE VICINITY OF THIS APPLIANCE WHILE IT IS IN OPERATION.
- Even after use, the burners remain hot for a long period; to avoid burning, do not place hands or other objects on them.
- After using the appliance, ensure that all the controls are in the closed or off position.

AUTOMATIC ELECTRIC IGNITION OF COOKTOP BURNERS

Push lightly the knob (A) which corresponds to burner to be ignited and turn anti clockwise to the "Full On" position, then depress the control knob. Automatically the ignition spark shoots. If there is no electric power the burner may be lit with matches.

OPTIMUM USE OF COOKTOP BURNERS

- In order to achieve maximum efficiency with minimum gas consumption it is useful to remember:
- Do not use large burners with pans of small diameter in order to avoid flames spreading wider than pans (consult the following table) and always use pans with lids (fig. 3).
 - When the boiling point is reached, it is best to turn the knob to the "Low position".
 - Avoid using over sized pans that may radiate excessive heat and cause damage to surrounding surfaces such as bench tops and glass lid.
 - Do not place anything, e.g. flame tamer, asbestos mat, between pan and pan support, as serious damage to the appliance may result (fig. 4).
 - Locate pan centrally over the burner so that is stable and does not overhang the appliance (fig. 5).
 - If gas burns with a yellow flame, do not continue to use burner and arrange for service.
 - Do not use burners without the proper pan support or wok stand, as this will concentrate and deflect the heat onto the hotplate (fig. 6) and surrounding surfaces.
 - Use only a wok support supplied or recommended by the manufacturer of the appliance (fig. 7).

ABNORMAL OPERATION

Any of the following are considered to be abnormal operation and may require servicing:

- Yellow tipping of the hob burner flame.
- Sooting up of cooking utensils.
- Burners not igniting properly.
- Burners failing to remain alight.
- Burners extinguished by the oven door.
- Gas valves, which are difficult to turn.

In case the appliance fails to operate correctly, contact our Service Centre.

Warning: Servicing should be carried out only by authorised personnel.

Burners	Ø pan cm
Wok	22 - 24
Medium	18 - 20
Small	16 - 18
Auxiliary	12 - 14

INSTRUCTIONS FOR THE USER

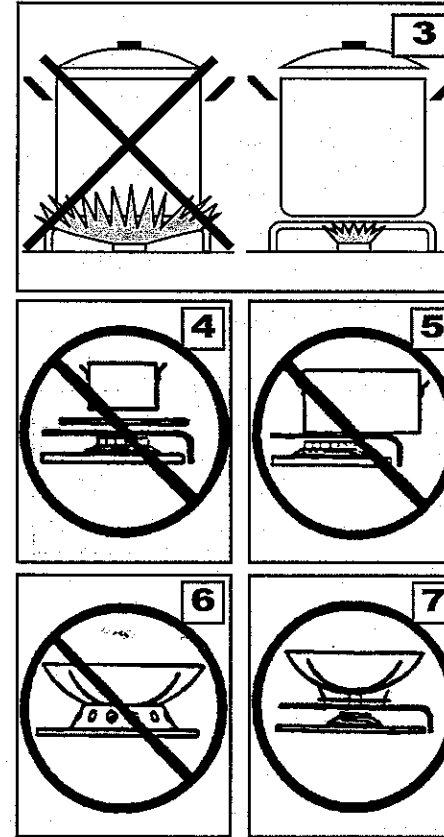

OVEN: GENERAL SAFETY INSTRUCTIONS

- Do not leave the oven unsupervised during use. Ensure that children and the infirm do not play with the appliance.
- DO NOT SPRAY AEROSOLS IN THE VICINITY OF THIS APPLIANCE WHILE IT IS IN OPERATION.
- WHERE THIS APPLIANCE IS INSTALLED IN MARINE CRAFT OR IN CARAVANS, IT SHALL NOT BE USED AS A SPACE HEATER.
- Always grip the centre of the oven door when opening. Do not practice excessive pressures on the door when it is open.
- DO NOT USE OR STORE FLAMMABLE MATERIALS IN THE APPLIANCE STORAGE DRAWER OR NEAR THIS APPLIANCE.
- Do not worry if condensation forms on the door and on the internal walls of the oven during cooking. This does not compromise its efficiency.
- When opening the oven door, be very careful of scalding vapours.
- During use the appliance becomes hot. Care should be taken to avoid touching heating elements inside the oven. Wear oven gloves when placing or removing pans from the oven or use the handle (D) (fig. 2) provided. Hook the handle to the edge of the tray and pull it out, slightly lifting it as you do so.
- WARNING: Accessible parts may become hot during use. To avoid burns young children should be kept away.
- When inserting or removing food from the oven, check that excess juices do not overflow onto the oven base (oils and fats are highly inflammable when overheated).
- Use containers that will resist the temperatures indicated on the thermostat knob.
- Never cover the base of the oven or the oven shelf with aluminium foil or other materials, as this creates a fire hazard.
- WARNING: Accessible parts may become hot when the grill is in use. Children should be kept away.
- When grilling always put a little water in the grill pan. The water prevents the grease from burning and from giving off bad smells and smoke. Add more water during grilling to compensate for evaporation.
- After using the appliance ensure that all the controls are in the off position.

Prior to any cleaning, disconnect the appliance from the electricity mains.

INSTRUCTIONS FOR THE USER

HOW TO USE THE MULTIFUNCTION OVEN

DEFROSTING AT ROOM TEMPERATURE

Turn the selector knob to the symbol and place the food you want to defrost inside the oven. The length of time required depends on the quantity and type of food. Selecting this function will only activate the fan. Mild air circulation around frozen food will slowly defrost it. It is particularly suitable for fruit and cakes.

TRADITIONAL COOKING

Turn the selector knob to the symbol and adjust the thermostat knob to suit the desired temperature. If pre-heating is recommended wait till the thermostat yellow led turns off before placing foods inside the oven. This option turns on both bottom and top heating units, evenly distributing heat on your foods. This type of cooking is ideal for all kind of foods (meats, fish, bread, pizzas, cakes..).

COMBINED TRADITIONAL + FAN COOKING

Turn the selector knob to the symbol and adjust the thermostat knob to suit the desired temperature. If pre-heating is recommended wait till the thermostat yellow led turns off before placing foods inside the oven. This option turns on both bottom and top heating units, and heat is distributed by fan ventilation. This combination is suitable for rapid cooking and allows for the use of more plates positioned on the different levels of the oven.

DEFROSTING + WARM UP BY HOT AIR

Turn the selector knob to the symbol and set the temperature on the thermostat knob, now place the food inside the oven. Selecting this function will activate the bottom heating unit and its heat is distributed by the fan. This function is particularly recommended to defrost and warm up ready-made meals.

FAN + REAR HEATING COMBINED COOKING

Turn the selector knob to the symbol and set the thermostat to the desired temperature, then place your food the oven. If oven needs pre-heating wait till the thermostat yellow led turns off before placing foods inside it. This function activates the rear heating unit and the fan distributes the heat produced. This combination allows for a fast and even cooking of several different foods placed on the diverse levels of the oven (fig.8).

CONVENTIONAL GRILL COOKING

Turn the selector knob to the symbol and set the thermostat to the desired temperature. Selecting this function the top central heating element turns on and heat is distributed directly on food surface. Apart from grilling, this function is ideal to add a golden roast to your recipes or to toast bread slices. The grill function automatically activates the eventual spit. When you use the grill, do not forget to place the drip pan beneath it to collect any sauce dripping, as suggested in the "USEFUL COOKING TIPS" section.

FAN GRILL COOKING

Turn the selector knob to the symbol and set the thermostat to the desired temperature (MAX 200°C). Selecting this function the top central heating element turns on and heat is distributed by the fan. This procedure mitigates the direct heat on food surface and uses milder temperatures. It is therefore recommended for an even golden and crispy finish touch, ideal for whole fish and poultry. The grill function automatically activates the eventual spit. When you use the grill, do not forget to place the drip pan beneath it to collect any sauce dripping, as suggested in the "USEFUL COOKING TIPS" section.

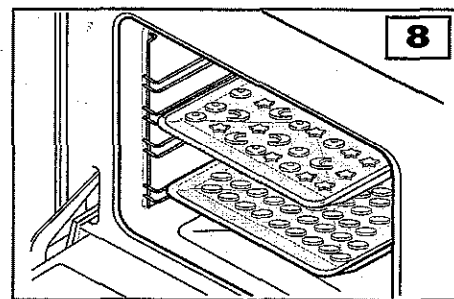

INSTRUCTIONS FOR THE USER

USEFUL COOKING TIPS

Cakes and bread:

- Heat the oven for at least 15 minutes before you start cooking bread or cakes.
- Do not open the door during baking because the cold air would stop the yeast from rising.
- When the cake is cooked turn the oven off and leave it in for about 10 minutes.
- Do not use the enamelled oven tray or drip pan, supplied with the oven, to cook cakes in.
- How do you know when the cake is cooked? About 5 minutes before the end of cooking time, put a cake tester or skewer in the highest part of the cake. If it comes out clean the cake is cooked.
- And if the cake sinks? The next time use less liquids or lower the temperature 10°C.
- If the cake is too dry: Make some tiny holes with a toothpick and pour some drops of fruit juice or spirits on it. The next time, increase the temperature 10°C and set a shorter cooking time.
- If the cake is too dark on top: the next time put the cake on a lower shelf, cook it at a lower temperature and longer.
- If the top of the cake is burnt: cut off the burnt layer and cover with sugar or decorate it with cream, jam, confectioner's cream, etc..
- If the cake is too dark underneath: the next time place it on a higher shelf and cook it at a lower temperature.
- If the cake or bread is cooked nicely outside but is still uncooked inside: the next time use less liquids, cook at a lower temperature and longer.
- If the cake will not come out of the tin: slide a knife around the edges, place a damp cloth over the cake and turn the tin upside down. The next time grease the tin well and sprinkle it with flour or bread crumbs.
- If the biscuits will not come away from the baking tray: put the tray back in the oven for a while and lift the biscuits up before they cool. The next time use a sheet of baking parchment to prevent this happening again.

Meat:

- If, when cooking meat, the time needed is more than 40 minutes, turn the oven off 10 minutes before the end of cooking time to exploit the residual heat (energy saving).
- Your roast will be juicier if cooked in a closed pan; it will be crispier if cooked without a lid.
- Normally white meat, poultry and fish need medium temperatures (less than 200°C).
- To cook "rare" red meats, high temperatures (over 200°C) and short cooking times are needed.
- For a tasty roast, lard and spice the meat.
- If your roast is tough: the next time leave the meat to ripen longer.
- If your roast is too dark on top or underneath: the next time put it on a higher or lower shelf, lower the temperature and cook longer.
- Your roast is underdone? Cut it in slices, arrange the slices on a baking tray with the gravy and finish cooking it.

Grilling:

- Sparingly grease and flavour the food before grilling it.
- Always use the drip pan to catch any dripping from the meat during grilling. Always pour a little water in the drip pan. It will prevent grease and sauces from burning avoiding burnt smells and smoke. Add more water during cooking to compensate for evaporation.
- Turn the food half way through cooking.

The aluminium can be easily corroded if it comes into contact with organic acids present in the foods or added during baking (vinegar, lemon juice). Therefore it is advised not to put directly the foods on aluminium or enamelled trays, but ALWAYS use the proper oven paper.

INSTRUCTIONS FOR THE USER

NATURAL CONVECTION AND FORCED CONVECTION COOKING / BAKING TIMETABLE

FOODS	Weight kg	Position of the oven shelf from the bottom	COOKING BY NATURAL CONVECTION		COOKING BY FORCED CONVECTION (with fan)	
			Temperatures in °C	Cooking time in min	Temperatures in °C	Cooking time in min
MEAT						
Roast veal	1	2	200-225	100-120	190	100-120
Roast beef	1	1	200-225	40-50	190	40-50
Roast pork	1	2	200-225	100-120	190	100-120
Roast lamb	1	1	200-225	100-120	190	100-120
GAME						
Roast hare	1	2	200-Max	50-60	200-Max	50
Roast pheasant	1	2	200-Max	60-70	200-Max	60
Roast partridge	1	2	200-Max	50-60	200-Max	50
POULTRY						
Roast chicken	1	2	200-225	80-90	190	70-80
Roast turkey	1	2	200-225	100-120	190	90-110
Roast duck	1	2	200-225	90-110	190	80-100
FISH						
Roast fish	1	2	200	30-35	170-190	25-30
Casserole fish	1	2	175	20-25	160-170	15-20
BAKED PASTA						
Lasagne	2.5	1	210-225	60-75	225-Max	30-40
Cannelloni	2.5	1	210-225	60-75	225-Max	30-40
PIZZA	1	2	225-Max	25-30	225-Max	20-25
BREAD	1	2	225-Max	20-25	220	20
PASTRIES						
Biscuits in general		2	190	15	170-190	15
Shortcrust pastry		2	200	20	190-200	20
Victoria sponge	0.8	2	200	40-45	190-200	40-45
CAKES						
Angel cake	0.8	2	190	52	170-190	45
Fruit cake	0.8	2	200	65	190-200	65
Chocolate cake	0.8	2	200	45	190-200	45

The values given in the tables (temperatures and cooking times) are approximate and may vary according to each person's cooking habits. This table gives cooking times on only one shelf. If you are cooking with a fan oven and you are using more than one shelf (placing the shelves on the 1st and 3rd position) cooking time will be about 5 to 10 minutes longer.

GRILLING TABLE

FOODS	Weight kg	Position of the oven shelf from the bottom	COOKING BY NATURAL CONVECTION		COOKING BY FORCED CONVECTION (with fan)			
			Temperatures in °C	Cooking time in min		Temperatures in °C	Cooking time in min	
				1st side	2nd side		1st side	2nd side
MEAT								
Chop	0.50	3	225-Max	12-15	12-15	200	15	10
Beefsteaks	0.15	3	200-225	5	5	=	=	=
Half chicken (each half 0.5 kg)	1	2	225	20	20	=	=	=
FISH								
Trout	0.42	3	225-Max	=	=	200	10	10
Sole	0.20	3	225-Max	=	=	200	7	7
BREAD								
Toast		3	225-Max	2-3	2-3	200	2-3	2-3

The values given in the tables (temperatures and cooking times) are approximate and may vary according to each person's cooking habits. In particular, temperatures and times for grilling meat will greatly depend on the thickness of the meat and on personal tastes.

INSTRUCTIONS FOR THE USER

CLEANING AND MAINTENANCE

- Prior to any maintenance work or cleaning, disconnect the appliance from the electricity mains.
- Do not wash the parts if they are still hot.
- Do not leave vinegar, coffee, milk, salty water or the juice of lemon or tomato on enamelled surfaces for any length of time.

To keep the surface of the hob and the various components in pristine condition (grill, enamelled covers, burner heads and flame diffusers, it is very important to wash them in warm soapy water, rinse and dry them well after each use.

WARNINGS

- Check that the heads burners and the relative burner caps, are correctly positioned in their housings (fig. 9).
- Take care not to disturb the ignition spark plugs or flame failure devices.
- If you find a tap is difficult to open or close do not force it but call for technical assistance urgently.

STRUCTURE

All the cooker parts (in enamelled or painted metal, steel, or glass) should be cleaned frequently with warm soapy water and then rinsed and dried with a soft cloth. DO NOT wash the parts if they are still hot.

OVEN CAVITY

Do not spray or wash the thermostat bulb with acid based products (check the product label before use). The manufacturer cannot be held liable for any damage caused by incorrect cleaning.

The oven cavity should be cleaned after each use to remove cooking residuals and or grease or sugar which, if burnt on when the oven is used again, will form deposits or unremovable stains as well as unpleasant smells.

To maintain the shine of the enamelled parts, clean them with warm soapy water, rinse and dry them thoroughly. ALWAYS wash the accessories used.

OVEN SEAL

The oven seal guarantees the correct functioning of the oven. We recommend you:

- clean it, avoiding abrasive tools or products.
- check its state now and then.

If the oven door seal has become hard or is damaged, contact our Service Centre and avoid using the oven until it has been repaired.

HOW TO CLEAN THE INNER OVEN DOOR GLASS

One of the features of our cookers is that the inner oven door glass can be easily removed for cleaning without the aid of specialized personnel. Just open the oven door and remove the support securing the glass (fig. 10).

ATTENTION!!

This operation can be done also with the door fitted on appliance, but in this way, pay attention that when the glass is pulled upwards, the force of the hinges can close the door roughly.
LOCK AT LEAST ONE HINGE (fig.12)

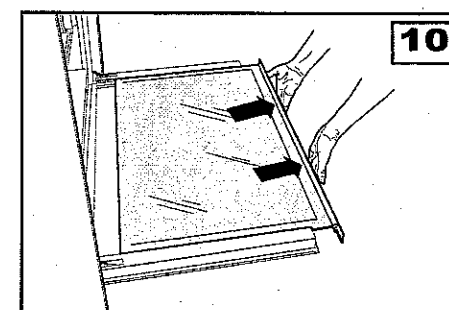
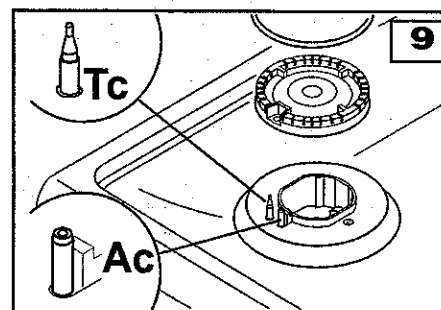

INSTRUCTIONS FOR THE USER

OVEN SIDEWALL GRIDS (fig. 11)

For an effective cleaning of the oven side-guide rails, these can be extracted unscrewing knurled nuts (G). To fit the rails back in their place, first insert rear pins in holes and then secure them with the knurled nuts (G).

OVEN DOOR REMOVAL (fig. 12)

The oven door can be removed to give easier access to the oven when cleaning.

To remove, proceed as follows:

- Open the oven door and insert rivet or nail (R) in the hole (F) of the hinge.
 - Partially close the door, forcing it upwards at the same time to free stop tooth and hinge sector.
- Once the hinge is free, pull the door forwards tilting it slightly upwards to free sector.
- To reassemble proceed in the reverse order, paying attention to the correct position of sectors.

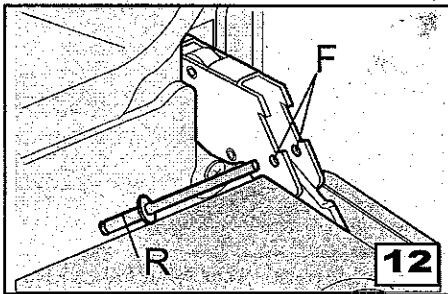
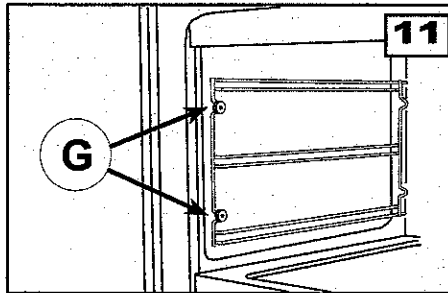

REPLACING THE OVEN LAMP

Ensure the appliance is switched off before replacing the lamp to avoid the possibility of electric shock.

In the event one or both oven lamps need replacing, the new lamps must comply with the following requisites: 15 W - 230 V - 50 Hz - E 14 - and must be resistant to high temperature (300°C).

The appliance can have two different types of lamp holder:

- **Lamp holder type 1 (fig. 13):** Draw out the side guide rails as described above. Then, remove the glass protection cap (V) from the bulb socket, lifting it with a screwdriver placed between the cap and the oven wall and replace the lamp (L). Fit the accessories back in reverse order.

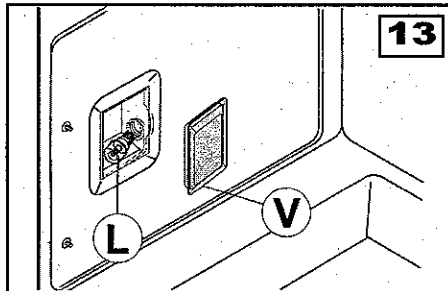

INSTRUCTIONS FOR THE INSTALLER

TECHNICAL INFORMATION

- The installations, conversions and maintenance operations listed in this part must only be carried out by authorised personnel. The manufacturer cannot be held responsible for any damage to persons or property resulting from an incorrect installation of the appliance.
- If the appliances is installed on a base, measures must be taken to prevent the appliance from slipping from the base
- The appliance is not intended to be operated by means of an external timer or separate remote-control system.

- The safety and automatic adjustment devices of the appliances may, during its life, only be modified by the manufacturer or duly authorised supplier.
- This appliance shall be installed only by authorised personnel and in accordance with the manufacturer's installation instructions, local gas fitting regulations, municipal building codes, electrical wiring regulations, AS 5601 - Gas Installations and any other statutory regulations.
- Failure to install the appliance correctly could invalidate any manufacturer's warranty and lead to prosecution under the above quoted regulation.
- Before installation, make sure that local distribution conditions (gas and electrical) are compatible with the appliance's adjustment. Refer to data label for gas type.
- As it is not connected to a device for the evacuation of the products of combustion, it must be installed in accordance with current regulations and used in a well ventilated location. Particular attention must be paid to the regulations on ventilation.

VENTILATION

All rooms require an openable window or equivalent, while some rooms require a permanent vent in addition to the openable window.

Ventilation must be in accordance with AS5601 - Gas Installations. In general, the appliance should have adequate ventilation for complete combustion of gas, proper flueing and to maintain temperature of immediate surroundings within safe limits.

The use of a gas appliance results in production of heat and moisture in the room in which it is installed. Ensure that the kitchen is well ventilated; keep natural ventilation holes open or install a mechanical

ventilation device (mechanical extraction hood). Prolonged intensive use of the appliance may call for additional ventilation, for example increasing the level of mechanical ventilation where present.

UNPACKING YOUR COOKER

- Once the packaging has been removed, thoroughly check that the appliance is in perfect condition. If you have any doubts do not use the appliance and call our Service Centre.
- Do not move the appliance by the handles.
- Some parts mounted on the appliance are protected by a plastic film. This protection must be removed before using the appliance. We recommend slitting the plastic film along the edges with a sharp knife or pin.

The packaging materials used (cardboard, plastic bags, polystyrene foam, nails etc.) must not be left anywhere within easy reach of children as they are a potential hazard source.

Maintenance Schedule

The appliance should be checked by an authorised person every year to ensure the safe operation of the appliance. As part of the inspection, the authorised person should also check that the wall brackets are engaged and securely mounted to the wall. This maintenance is not covered by warranty.

INSTRUCTIONS FOR THE INSTALLER

POSITION (fig. 14)

The appliance should be positioned in good light and free from draughts. Any adjoining wall surface situated within 200 mm from the edge of any hob burner must be a suitable non-combustible material for a height of 150 mm for the entire length of the hob. Any combustible construction above the hotplate must be at least 750 mm above the top of the burner and no construction shall be within 450 mm above the top of the burner.

Where a combustible surface adjacent to the cooker is less than 200 mm from the nearest burner it may be protected by a non-combustible protective layer in accordance with AS5601. The protection must ensure the surface temperature of the combustible surface does not exceed 65° C above ambient.

LEVELLING THE COOKER

- **Adjustable feet**, This model has very slight adjustable feet which can go from a height of 900 - 920mm It has full plinths on both sides.(fig.15)
- **Backguard**, The cookers which are equipped with this accessory, leave the factory with this part inserted inside the packaging. In order to install the backguard, it is necessary to loosen the screws positioned on the back of the hob and then to fix the backguard as indicated in figure 17.

OVERALL DIMENSIONS (fig. 15)

900 - 920H x 900W x 600D mm

It is essential to check dimensions of physical product when measuring for installation and before doing any cut outs.

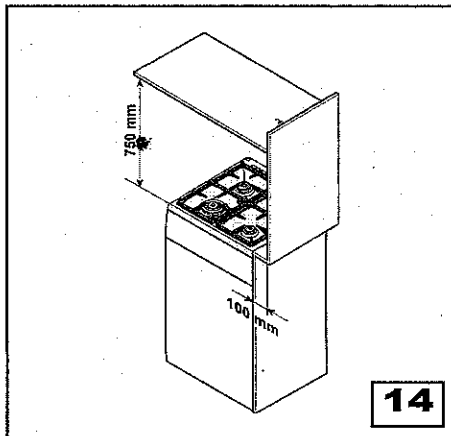

14

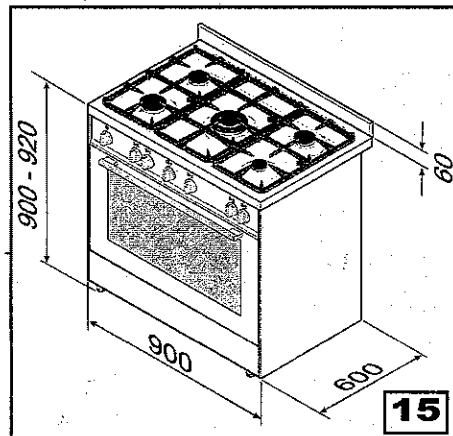

15

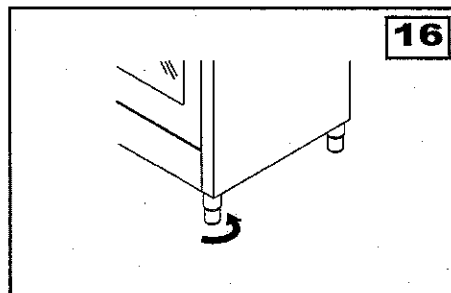

16

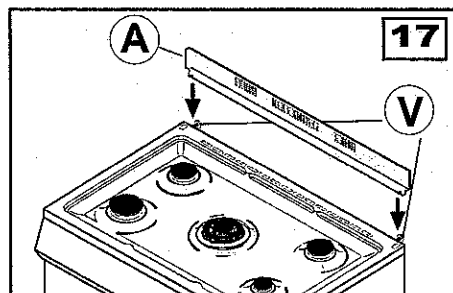

17

INSTRUCTIONS FOR THE INSTALLER

INSTRUCTION FOR STABILIZING THE COOKER

The installation of the brackets provided is for safety reasons and must be installed as indicated below.

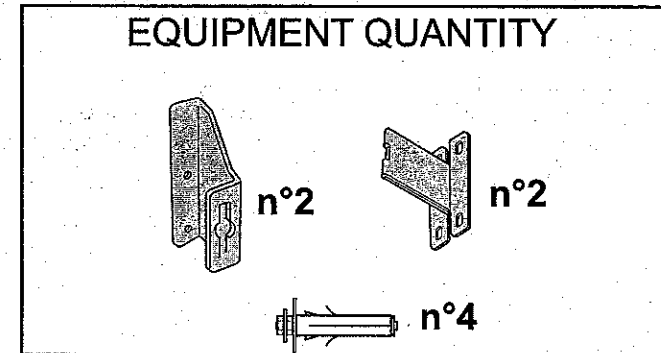

WARNING: In order to prevent the cooker tipping forwards in the event of children standing on the oven door or where users put extreme weight on the door when in open position, the stabilising means must be installed by the installer. Failure to fit the stabilising brackets properly may cause personal burn injuries and damage to the gas pipe.

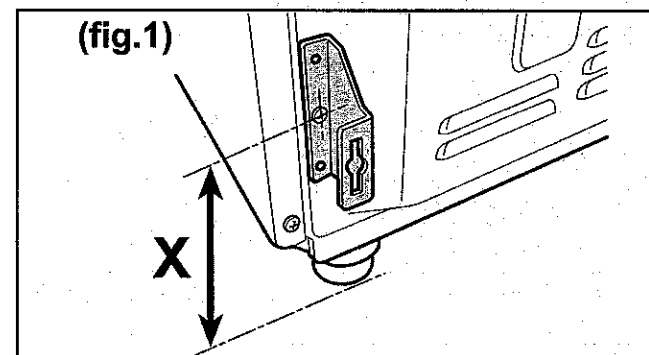

Fix the bracket on the cooker.

One for each side.

Align the cooker with the surrounding cupboard.

Measure the distance from the floor and from the fixing point of the bracket.(X)

INSTRUCTIONS FOR THE INSTALLER

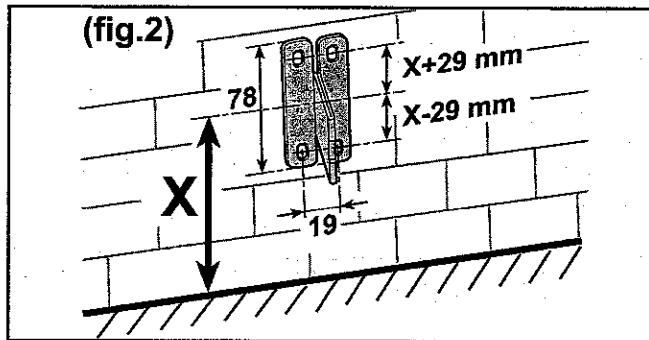

Mark it the same distance, (X) on back wall.

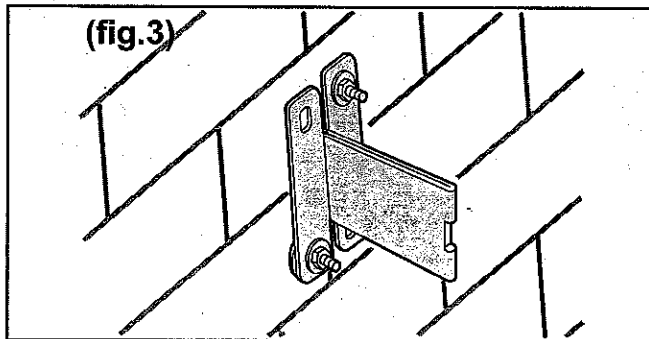

Drill two holes in the wall for each bracket according to the fig. 2 and fix the bracket.

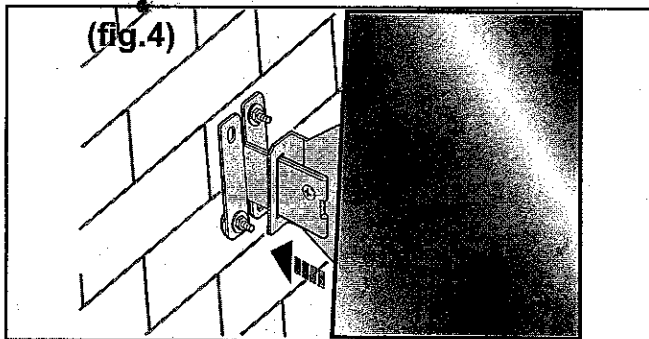

Push back the cooker against the wall.

IMPORTANT: After fitting the stabilising brackets and pushing the cooker into position, check that the cooker does not tilt forward or sideways

Hose Restraint Chain

The installer must fit a chain, no more than 80% of the hose length to ensure that there is no strain on the hose when the cooker is pulled forward. Attach one end of the chain as close as possible to the gas inlet on the cooker and the other end as close as possible to the gas outlet on the wall. Suitable chain and fittings are to be supplied by the installer.

INSTRUCTIONS FOR THE INSTALLER

ELECTRICAL CONNECTION

The electrical connection must be carried out in accordance with the current standards and laws in force.

WARNING:

IF THE SUPPLY CORD IS DAMAGED, IT MUST BE REPLACED BY THE MANUFACTURER, ITS SERVICE AGENT OR SIMILARLY QUALIFIED PERSONS IN ORDER TO AVOID A HAZARD.

Before connecting check that:

- The system and electrical sockets amperage is adequate for the appliance maximum power (see data label affixed on the back of the cooker).
- The socket or system has an effective earth connection in accordance with current standards and prescriptions of the law. All responsibility is disclaimed if this is not complied with.
- The plug and socket or the multipolar switch must be accessible after installation of the appliance.
- If the appliance has no power cable, connect one with a suitable cross section to the terminal board (see paragraph «CONNECTING THE POWER CABLE»).

When connecting to the mains with a socket:

- Fit to the power cable (if without) a standardized plug, suitable for the load which is indicated on the data label. Connect the wires making sure they correspond as shown below, and remember that the earth wire must be longer than the phase wires:

letter L (phase) = brown wire

letter N (neutral) = blue wire

symbol ⊕ (earth) = green/yellow wire

- The power cable must be laid so that no parts of it ever reach a temperature of 75 °C.
- For connecting do not use adapters or shunts as they could cause false contacts resulting in

hazardous overheating.

When connecting directly to the mains:

- If the appliance is not fitted with a supply cord and a plug, or with other means for disconnection from the supply mains having a contact separation in all poles that provide full disconnection under overvoltage category III conditions, then a means for disconnection must be incorporated in the fixed wiring in accordance with the wiring rules.
- Install a multipolar switch that can withstand the appliance load, with a minimum opening between the contacts of 3 mm.
- Remember that the earth wire must not be cut out by the switch.

CONNECTING THE POWER CABLE

The combi cookers leave the factory ready for single-phase power, but they can, with due modifications, be powered by three phase systems by following these instructions:

- Remove the rear panel from the cooker.
- Move the connecting plates in the terminal board according to the type of connection you want, following the diagram in fig. 18. You will also find this diagram affixed to the back of the cooker.
- Connect the power cable, whose cross section must be suitable (see table on <TECHNICAL FEATURES> paragraph) keeping the earth wire longer than the phase wires.
- Secure the cable in the clamp and - fit the rear panel in place.

18

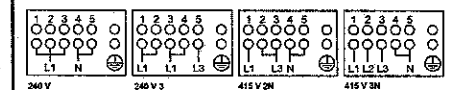

INSTRUCTIONS FOR THE INSTALLER

GAS CONNECTION

This appliance shall be installed only by authorised personnel and in accordance with the manufacturer's installation instructions, local gas fitting regulations, municipal building codes, water supply regulations, electrical wiring regulations, AS 5601 - Gas installations and any other statutory regulations.

The appliance is adjusted to work at gas indicated on the label which is applied on the glass-window of the oven door and on the cooker packing.

Installation for Natural gas

Connected regulator (B) to fitting (A) which is then fitted to elbow (F). Ensure arrow on regulator point in the direction shown. Fitting (D) to be supplied by installer (fig. 19). Adjust regulator to give test-point pressure given on data label (see on **TECHNICAL FEATURES** paragraph), with one large or one medium burner alight at maximum.

Position of Regulator (fig. 19)

The stove must be installed on legs, a gas pipe between fitting (A) and (B) will allow location of the regulator (B) underneath the stove for adjustment and maintenance

Installation for Propane Gas

Connect by using a copper pipe starting, from the threaded fitting of elbow (F).

Note: When the regulator is fitted at the rear of the cooker at least 60 mm clearance is required.

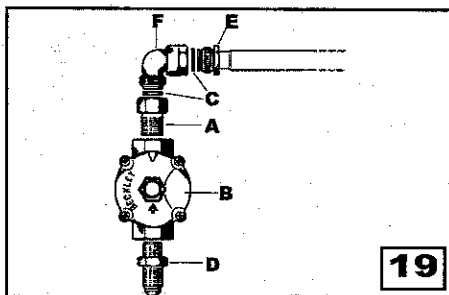

Installation using flexible connection

As an option, the cooker may be installed with a flexible connection: hose, which complies with AS/NZS 1869 (AGA Approved); 10 mm ID, class B or D, Minimum 1000 mm - Maximum 1200 mm, as an alternative connection.

- All cookers offer left or right hand connection. The manifold has a flat flair over which is inserted a screw nut male 1/2" gas (fig 20).
- An isolating tap and pressure regulator must be fixed to the rear wall and the flexible pipe attached by means of a union connector.
- The gas connection and isolating tap must be accessible to a service person or inspector.
- The hose assembly must be installed in accordance with AS5601 for a high level connection. The hose should not be subjected to abrasion, kinking or permanent deformation and should be able to be inspected along its entire length. Unions compatible with the hose fittings must be used and connections tested for gas leaks. The fixed consumer piping outlet should be at approximately the same height as the cooker connection point, pointing downwards.
- The hose should be clear of the floor when the cooker is in the installed position. The hose restraint chain supplied should be anchored to the lower hook fixed to the wall so that the chain prevents strain on the hose connections when the cooker is pulled forward.
- Before Leaving - Check all connections for gas leaks with soap and water. **DO NOT** use a naked flame for detecting leaks. Ignite all burners both individually and concurrently to ensure correct operation of gas valves, burners and ignition. Turn gas taps to low flame position and observe stability of the flame for each burner individually and concurrently. When satisfied, please instruct the user on the correct method of operation. In case the appliance fails to operate correctly after all checks have been carried out, refer to the authorised service provider in your area.

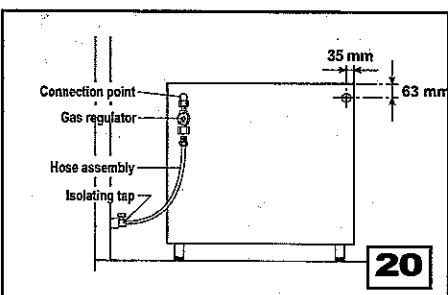

INSTRUCTIONS FOR THE INSTALLER

ADJUSTMENTS

- Always disconnect the appliance from the electricity supply before making any adjustment.
- All seal must be replaced by the technician following any adjustment or regulation.
- The adjustment of the reduce rate (simmer) must be undertaken only with burners functioning on natural gas while in the case of burners functioning on L.P.G, the screw must be locked down fully (in clockwise direction).
- "Primary air adjustment" on hob gas burners is unnecessary.

TAPS

All gas taps are male cone type with only one way of passage. Adjustment of the "Reduced rate" position as follows:

- Turn the burner on and place the knob on the "Reduced rate" position (small flame).
- Remove the knob (A) of the tap which is attached by simply applying pressure to the rod.
- In the case of taps with flame failure device, the adjustment screw (V) is over or on the side of the stem (fig. 21).
- Check that the flame does not go out when the knob is sharply switched from the "Full on" to "Reduced rate" positions.

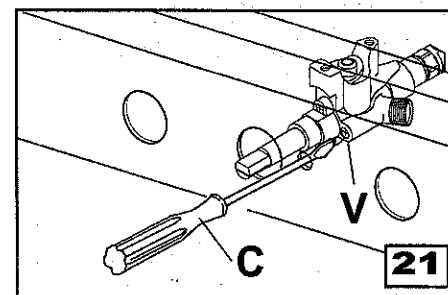

CONVERSIONS

REPLACING THE INJECTORS

Our burners can be adapted to different types of gas by simply installing the injectors suitable for the gas you want to use. To help the installer, in the table <TECHNICAL FEATURES> paragraph, gives the burner nominal heat input, injector diameter and operating pressure of the different gas types.

Comply with the following instructions:

Injector replacement - Hob burners.

To change the injectors on the hob, remove the burner cup and head and with a 7 mm Ø socket spanner replace them (fig.22)..

After having replaced the injectors, it will be necessary to proceed with burner adjustment as explained in the previous paragraphs. The technician must replace any seals after the adjustments have been made.

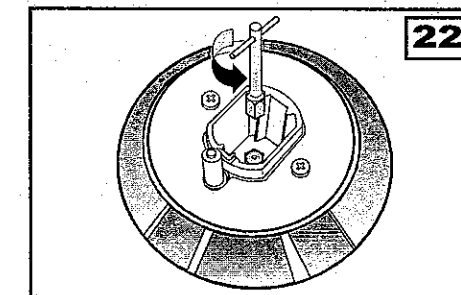

INSTRUCTIONS FOR THE INSTALLER

MAINTENANCE

Prior to any maintenance work or changing parts, disconnect the appliance from the gas and electricity power sources.

Warning: Servicing should be carried out only by authorised personnel.

REPLACING THE TAPS

Proceed in the following way when replacing a tap:

- Remove pan supports, burner heads.
- Unscrew the burner fixing screws (Vc) (fig. 23). (four for ultrarapid burner and two for the other burners)
- Pull out the knobs.
- Unscrew the six fixing screws (Vp) (fig.23) which lock the side profiles and remove it.
- Remove the hob, unscrewing rear fixing screws (Vs) (fig. 23) which lock the hob at the supports (S).
- Unscrew the nuts (D) of the gas aluminium pipes and pull out the thermocouple connectors (F) (fig.25).
- Unscrew the screws (Vt) (fig. 24) which lock the crosspieces.
- Unscrew the screws (Vb) (fig. 24) which unite the the bridles of the taps to the front frame.
- Make to slip the ramp toward the back part and unscrew the screws (Vb) (fig. 25) in order to free the taps.
- Change seal each time a tap or a thermostat is replaced. This will ensure perfect retention between the tap or a thermostat and part.

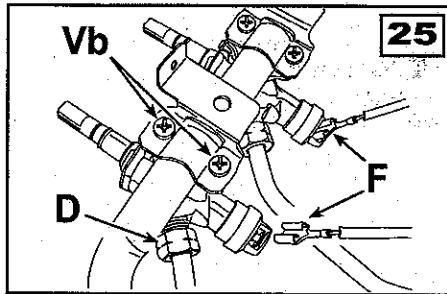
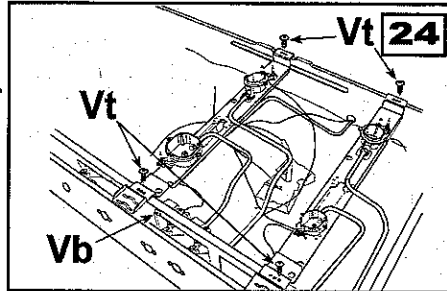

- Reassemble all the parts following the same procedure but in the reverse order

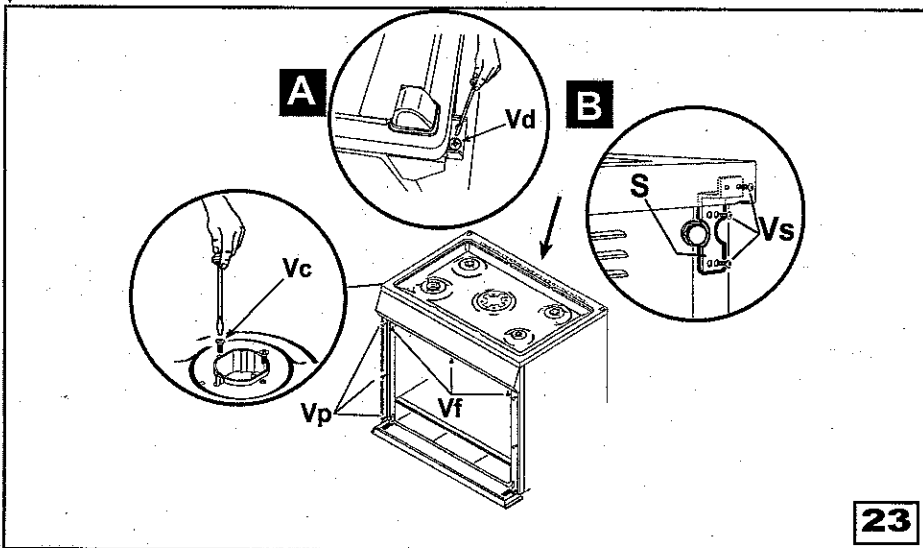

INSTRUCTIONS FOR THE INSTALLER

REPLACING THE ELECTRICAL COMPONENTS

- The rear protection will have to be removed in order to change the electrical heating elements, lamp holder, terminal board and power cable.
- If you have to change the power cable, always keep the earth wire longer than the phase wires and, in addition, follow all the instructions given in the "ELECTRICAL CONNECTION" paragraph.
- To replace the oven lamp please refer to instructions on REPLACING THE OVEN LAMP paragraph.
- To change the lamp-holder (P), type 1, force the tabs of blockage (M) and take the lamp-holder toward the outside of the oven (fig.26).
- To replace the ignition generator, remove the left side panel of the appliance.
- To change the thermostat, commutators or hob heating elements, the work top has to be removed.

CHANGING THE FLEXIBLE GAS HOSE

In order to guarantee that the gas hose is always in excellent condition we strongly recommend changing it on the date you will find printed on it.

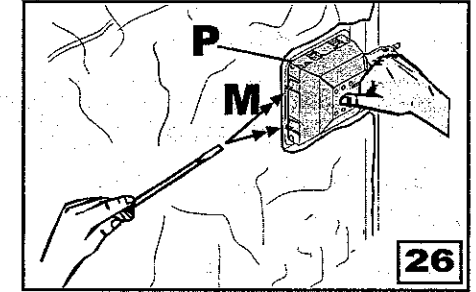

TROUBLESHOOTING

Some of the problems occur because of simple maintenance oversights or operation mistakes and can easily be resolved without having to call for technical assistance.

PROBLEM	REMEDY
The appliance is not working	<ul style="list-style-type: none"> • Make sure the gas cock is open • Check the plug is in • Check that the knobs are set correctly for cooking and then repeat the operations given in the handbook • Check the electrical system safety switches (RCD). If there is failure in the system call an electrician in.
The left electric oven is not working	<ul style="list-style-type: none"> • Check that the programmer accessory is on the manual position and then repeat the operations described in the manual
The thermostats are not working	<ul style="list-style-type: none"> • Call our Service Centre
The electric thermostat warning lights do not switch on during use	<ul style="list-style-type: none"> • Turn the thermostat round to a hotter temperature • Turn the selector round to a different function
The oven lights does not switch on	<ul style="list-style-type: none"> • Make sure the lamp is firmly screwed in place • Buy a lamp for high temperatures at one of our Service Centre and fit it following the REPLACING THE OVEN LAMP paragraph.

TECHNICAL FEATURES

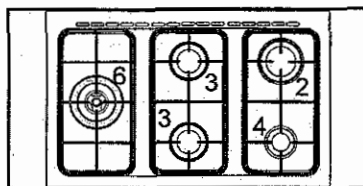
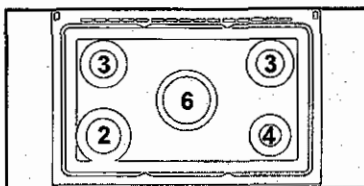

Burner disposition and hob burner technical data table

N.	Burner Denomination	Gas	Operating Pressure kPa	Diameter injectors Sabaf 1/100 Mm	Rating MJ/h
2	Large	U-LPG Natural	2.75 1.00	88 142	10.0 10.0
3	Medium	U-LPG Natural	2.75 1.00	73 120	7.2 7.2
4	Small	U-LPG Natural	2.75 1.00	54 90	3.8 4.0
6	Wok	U-LPG Natural	2.75 1.00	105 175	14.6 15

Electric components Description	Nominal data
Lower heating element	2100 W
Top heating element of the oven/grill	2000 - 2200 W
Grill heating element	2000 W
Rear circular heating element	3000 W
Oven lamp	15 W - E 14 - T 300
Cooling fan	12 W
Rear Fan motor	25..29 W
Cable type	H05 RR-F 3 x 1.5